



Rack Mount Two Channel
Power Amplifier 857
User Guide

MERIDIAN

Important safety instructions

- Read the instructions.
- Keep these instructions.
- Follow all instructions.
- Do not use this apparatus near water.
- Clean only with a dry cloth.
- Install only in accordance with the manufacturer's instructions.
- Refer all servicing to approved service personnel.
- Use only with the cart, stand, tripod, bracket, or table specified by the manufacturer, or sold with the apparatus. When a cart is used, use caution when moving the cart/apparatus combination to avoid injury from tip-over.



WARNING: TO REDUCE THE RISK OF FIRE OR ELECTRIC SHOCK, DO NOT EXPOSE THIS APPARATUS TO RAIN OR MOISTURE.

This apparatus has been designed with Class 1 construction and must be connected to a mains socket outlet with a protective earthing connection (the third grounding pin).

The apparatus may be isolated from mains power by switching off the mains power switch at the rear of the unit.

Climate

The equipment has been designed for use in moderate climates and in domestic situations.



Only use at an altitude not exceeding 2000m.

Safety warnings

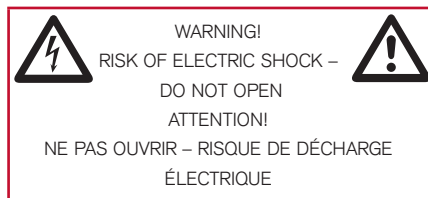

Caution: to reduce the risk of electric shock, do not remove cover. No user serviceable parts inside. Refer servicing to qualified service personnel.



The lightning flash with arrowhead symbol, within an equilateral triangle, is intended to alert the user to the presence of uninsulated "dangerous voltage" within the product's enclosure than may be of sufficient magnitude to constitute a risk of electric shock to persons.



The exclamation point within an equilateral triangle is intended to alert the user to the presence of important operating and maintenance (servicing) instructions in the literature accompanying the appliance.

- Do not expose the unit to dripping or splashing.
- Do not place any object filled with liquid, such as a vase, on the unit.
- Do not place naked flame sources, such as lighted candles, on the unit.
- The apparatus weighs over 36kg. Do not attempt to lift it without assistance.

To avoid overheating

- Leave at least 10cm around the equipment to ensure sufficient ventilation.

Do not position the product:

- In direct sunlight.
- Near heat sources, such as a radiator.
- On a soft surface such as a carpet.

The top and bottom of the Rack Mount Two Channel Power Amplifier 857 case contains venting holes for the internal heatsinks and fans which should not be obstructed. Ensure that air can flow through them without obstruction. The product normally runs warm to the touch when not in standby.

Radio interference

FCC Warning: This equipment generates and can radiate radio frequency energy and if not installed and used correctly in accordance with our instructions may cause interference to radio communications or radio and television reception. It has been type-tested and complies with the limits set out in Subpart J, Part 15 of FCC rules for a Class B computing device. These limits are intended to provide reasonable protection against such interference in home installations.

EEC: This product has been designed and type-tested to comply with the limits set out in EN55032:2015 and EN55024:2010 + A1:2015.



Copyright and acknowledgements

Sales and service in the UK

Meridian Audio Ltd
Latham Road
Huntingdon
Cambridgeshire
PE29 6YE
England

Tel (01480) 445678
Fax (01480) 445686

Sales and service in the USA

MAI
351 Thornton Road
Suite 108
Lithia Springs, GA
30122
United States

Tel 404-344-7111
Fax 404-346-7111

Designed and manufactured in the UK

Meridian Audio Ltd
Latham Road
Huntingdon
Cambridgeshire
PE29 6YE
England

Visit us on the Web

www.meridian-audio.com

Copyright © 2017 Meridian Audio Ltd.

Part no: P88453

Meridian is a registered trademark of Meridian Audio Ltd.

This guide was produced by:
Human-Computer Interface Ltd,
<http://www.interface.co.uk>

Product registration

Register your Meridian Rack Mount Two Channel Power Amplifier 857 at:

www.meridian-audio.com

General features

The Meridian Rack Mount Two Channel Power Amplifier is a rack mounting version of the Reference Two Channel Power Amplifier, designed for mounting in a standard 18" equipment rack. It is a solid, robust, two-channel unit, delivering a powerful 250W RMS per channel continuous into 8Ω, or over a kilowatt bridged into 4Ω.

The amplifier can be operated in bridge mode by setting a switch on the back panel, in which case the left channel input becomes the input for the bridged pair and the inner output terminals are bridged, power being derived from the outer terminal pairs.

The Rack Mount version is supplied without the glass top, protective side panels, or feet featured on the standard version, and has a solid aluminium front panel with rack mounting holes.

Design

The Meridian Rack Mount Two Channel Power Amplifier is based on modules that feature a symmetrical design with fully electronically-balanced inputs. Both balanced and unbalanced inputs are provided, and the unbalanced inputs are converted to balanced before they enter the amplifier itself using Meridian's proprietary 'superbal' technology.

The discrete active input components are thermally and electrically matched in a quad package and in pairs where appropriate, and the amplifiers feature active bias control throughout, with thermal sensing that carefully manages the temperature and current flow at different volume levels.

Fully DC-coupled, the signal path contains no unnecessary capacitors, while those in the power supplies are audiophile grade components.

The amplifiers are of a unique low-feedback design for minimum transient and intermodulation distortion, offering superb clarity and transparency right across the audible range, with an output impedance that is close to zero and suitable for virtually any high-quality third-party passive loudspeaker system.

Special attention has been paid to ensure that the amplifiers can deliver the power that's required at any given moment. A massive low-noise toroidal power transformer provides power to a generous five selected pairs of output devices per channel, carefully temperature-controlled for optimum operating characteristics and efficiency, and with thermal protection for reliability. The result is a clear, open sound with detail as well as punch where it's required.

Trigger and other control signals are optically isolated from the amplifier itself. When in standby mode, a standing voltage is maintained on the power rails and supply components. As a result, you only have to wait for a short time after switching on for optimum performance to be achieved.

Two sets of outputs are provided per channel, for bi-wiring, on sturdy WBT terminals colour-coded for easy reference and capable of handling large-diameter high-quality loudspeaker cables. The reservoir capacitors and output terminals are connected to the amplifier using 12 gauge 147 strand OFC silver-coated cable to maximise power transfer.

Control

The amplifier includes electronic protection, reset by power-cycling, with full DC and thermal protection.

Three temperature-controlled fans on each side of the case provide cooling for the internal heatsinks, and these operate at elevated temperatures only and features two speed settings to minimise generated acoustic noise.

A capacitive touch-sensitive logo allows you to switch the amplifier between on and standby, and its colour shows the status of the amplifier. In the event of overheating the channels will be taken offline.

A flexible 5-30V trigger capability allows amplifier power to be controlled remotely along with the rest of a system.

Specifications

Audio inputs

- 2-channel balanced XLR inputs (11k Ω).
- 2-channel RCA inputs (5.7k Ω).
- Switch for balanced/unbalanced per channel.
- Switch for bridge mode.

Audio outputs

- 4 WBT terminals per side, allowing bi-wiring.
- 2 x 250W into 8 Ω , or 2 x 500W into 4 Ω , bridgeable to >1000W.
- Assisted cooling operating at elevated temperatures only.

Characteristics

- Distortion less than 0.01%.
- Signal/noise better than -100dB.

Control signals

- Trigger input: 3.5mm 5-30VDC.

Front panel

- Capacitive touch-sensitive logo for on/standby.
- Illuminated colour-coded logo surround showing the amplifier status: standby, on, fans on, and overheated.

Physical

- Dimensions: 480mm x 175mm x 425mm (18.90" x 6.89" x 16.73") (W x H x D).
- Weight: 32kg (stand-alone version), 35kg (rack version).
- Stand-alone or rack-mounted versions.

Power

- Linear power supply with trip and soft start.
- 100V AC 50/60Hz.
- 110-120V AC 50/60Hz.
- 220-240V AC 50/60Hz.
- Three temperature-controlled fans per channel.

Meridian Audio reserves the right to amend product specifications at any time.

Unpacking

The Rack Mount Two Channel Power Amplifier is supplied with the following accessories:

- Power cord.
- Bridge-mode link.
- This manual.
- Four M6 captive nuts for 1.7mm to 2.7mm thick racks.
- Four M6 captive nuts for 2.7mm to 3.5mm thick racks.
- Four M6 screws for captive nuts.
- Four 10-32 screws for standard rack mounting.
- Four washers.

If any of these items are missing please contact your retailer.

NOTE: You should retain the packaging in case you need to transport the unit.

Rack mounting

Note: The Rack Mount Two Channel Power Amplifier weighs 35kg. We recommend two people lift it when positioning it for rack mounting.

- If necessary, fit the appropriate captive nuts to the four mounting positions on the rack.
- Hold the power amplifier in position and secure it with the four mounting bolts.

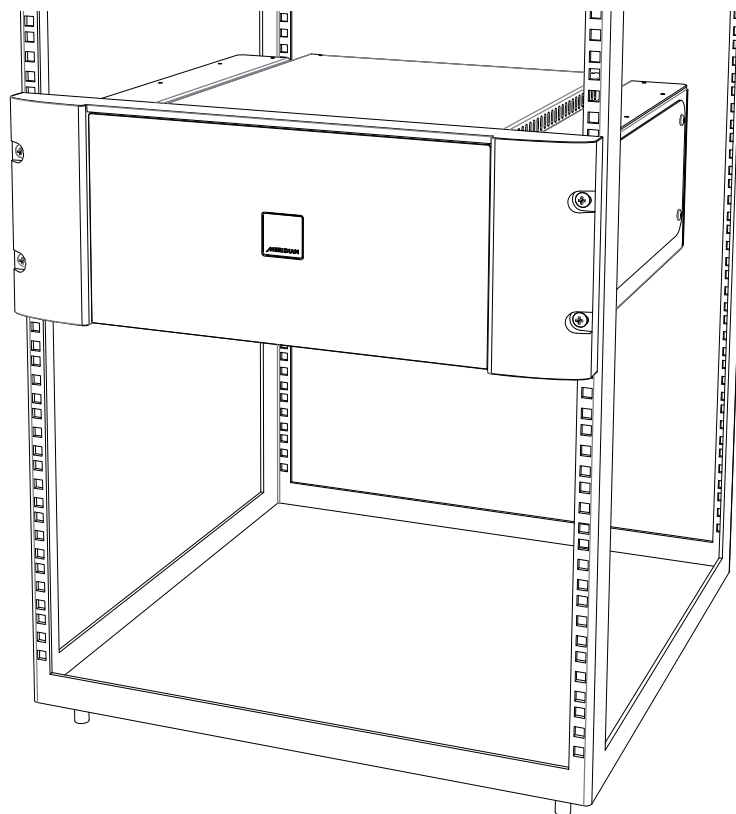

Siting

During normal operation the internal heatsinks may become quite hot. The power amplifier should therefore be positioned to allow a free flow of air through the cooling vents on each side of the case. Do not place the power amplifier:

- In direct sunlight.
- Near heat sources, such as a radiator.
- Stacked with any other audio products, as the heat it generates may damage the other products.
- On a soft surface, such as a carpet, which would obstruct the ventilation holes in the base.

Standby

Once set up, the power amplifier can be left in standby as it consumes minimal power in this mode.

If you are not going to use the power amplifier for a period of several days you should switch off the unit completely, at the back panel and disconnect it from the AC power supply.

Trigger input

The Trigger input can be used to bring the power amplifier out of standby by applying a signal from a control unit or preamplifier.

Operation

The indicator on the front panel shows the status of the amplifier:

Indicator	Status	Explanation
Blue	Standby.	Touch logo to turn the amplifier on after a four second startup period.
Green	Normal operation.	Fans off.
Amber	Normal operation.	Fans operating.
Red	Overheated.	Outputs muted. Fans operating. The outputs will unmute when the amplifier has cooled down.
Blank *	Tripped.	Amplifier off, caused by a fault, such as an input with a DC offset or a shorted output. Correct the fault, then reset by turning off the power at the back panel and then on again.

* Touching the logo for approximately four seconds will blank the indicator. Touch the logo for four seconds again to reenable it.

8 Rack Mount Two Channel Power Amplifier 857 User Guide

Back panel

The following diagram gives details of the back panel connections:

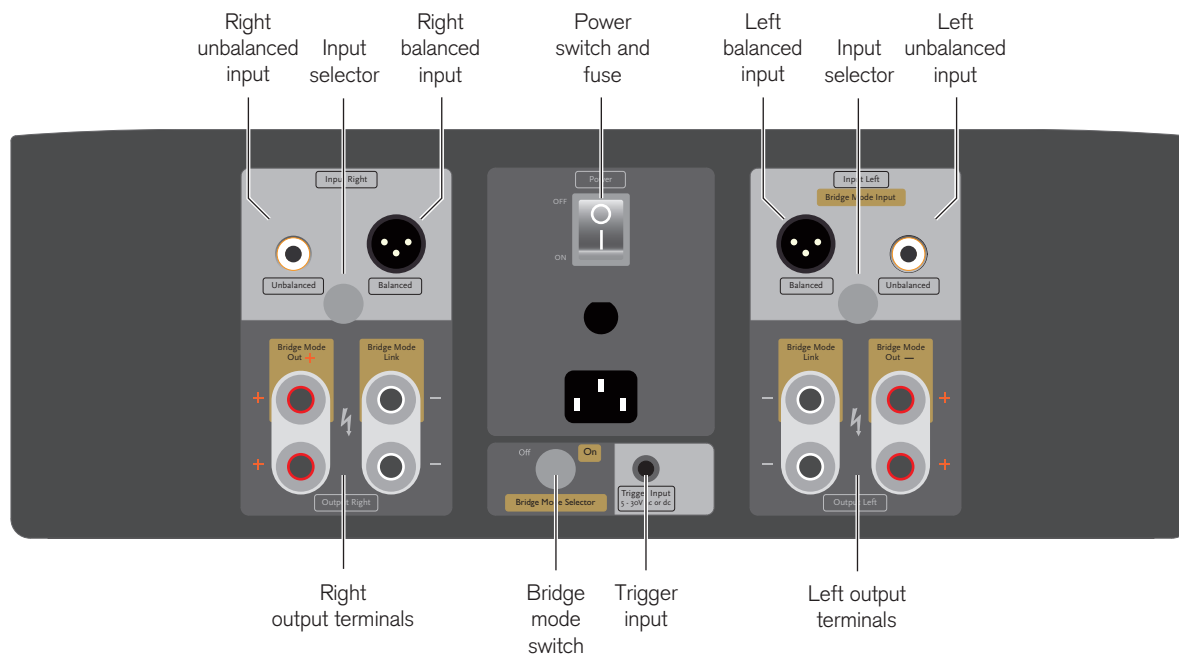

Audio inputs

Use this input

Balanced inputs

Unbalanced inputs

To connect to this

The outputs of a source with balanced outputs, using XLR cables.

The outputs of a source with unbalanced outputs, using phono cables.

Loudspeaker outputs

Use this output

Output Right +/–, Output Left +/–

To connect to this

Loudspeakers of between 4Ω and 8Ω.

Communications connections

Use this connection

Trigger input

To connect to this

The 5–30V trigger output from a preamplifier or control system.

Applications

To connect to an unbalanced preamplifier

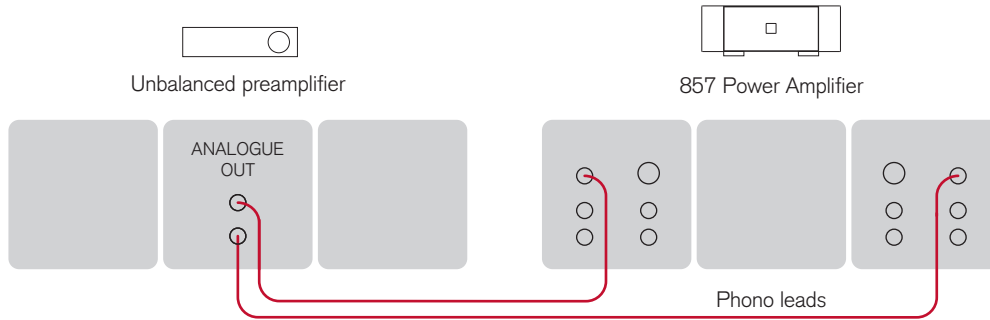

- Connect outputs from the preamplifier to the Unbalanced sockets on the power amplifier.
- Set the Bridge Mode Selector to the Off position.
- Switch the channels to the Unbalanced position.

You should either use a twin-screened audio cable, or a pair of single-screened audio cables.

To connect to a balanced preamplifier (eg Meridian Ultra Digital to Analogue Converter)

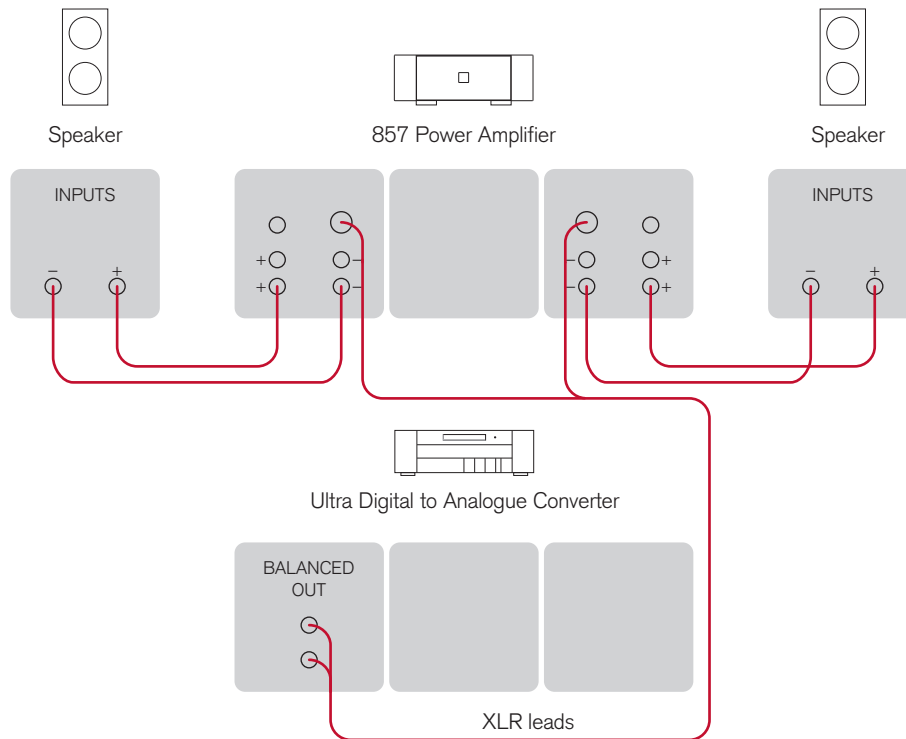

You can connect the Rack Mount Two Channel Power Amplifier to a preamplifier with balanced outputs, such as the Meridian Ultra Digital to Analogue Converter.

- Connect the balanced ANALOGUE OUTPUT connections from the Ultra Digital to Analogue Converter to the balanced inputs of the Rack Mount Two Channel Power Amplifier.
- Set the Bridge Mode Selector to the Off position.
- Switch the channels to the Balanced position.
- Optionally connect the Trigger 1 output from the Ultra Digital to Analogue Converter to the power amplifier Trigger input, to switch the power amplifier on and off automatically from the Ultra Digital to Analogue Converter.

To connect to passive loudspeakers

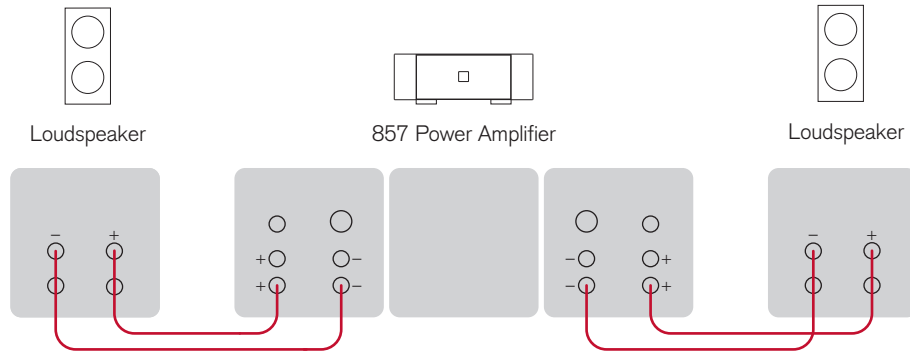

- Set the Bridge Mode Selector to the Off position.

- Connect one of each pair of the red and black terminals from the appropriate channel of the Rack Mount Two Channel Power Amplifier to the red and black terminals on the loudspeakers.

• To bi-wire to passive loudspeakers

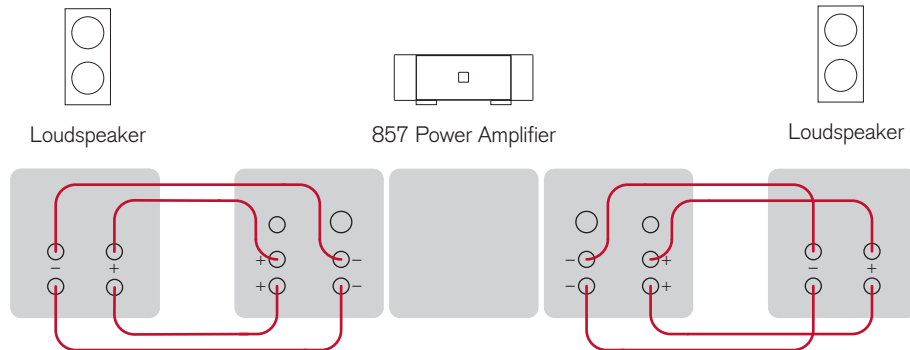

- Set the Bridge Mode Selector to the OFF position.

Important: Remove the links bridging the LF and HF terminals on the back of each loudspeaker.

- Connect the LF red and black terminals from each loudspeaker to the red and black terminals on the appropriate channel of the Rack Mount Two Channel Power Amplifier, using twin loudspeaker cable.
- Connect the HF red and black terminals from each loudspeaker to the other pair of red and black terminals on the appropriate channel of the Rack Mount Two Channel Power Amplifier.

12 Rack Mount Two Channel Power Amplifier 857 User Guide

To wire to a passive loudspeaker in bridge mode

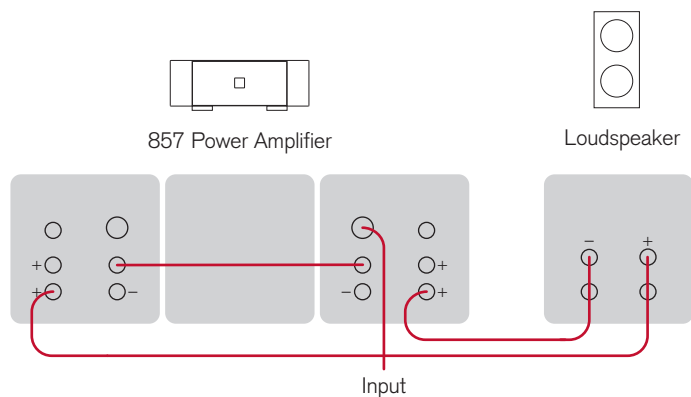

You can use the Rack Mount Two Channel Power Amplifier as a mono power amplifier, to obtain more than twice the power output, by wiring it in bridge mode.

- Set the Bridge Mode Selector to the On position.
- Fit the supplied bridge mode link between the left and right negative terminals.
- Connect the audio inputs to the Balanced or Unbalanced Bridge Mode input, as appropriate.
- Connect the loudspeaker between the Bridge Mode terminals.

You can bi-wire in bridge mode by using the other pair of Bridge Mode terminals to connect separately to the loudspeaker treble unit.

To bi-amp to two passive loudspeakers

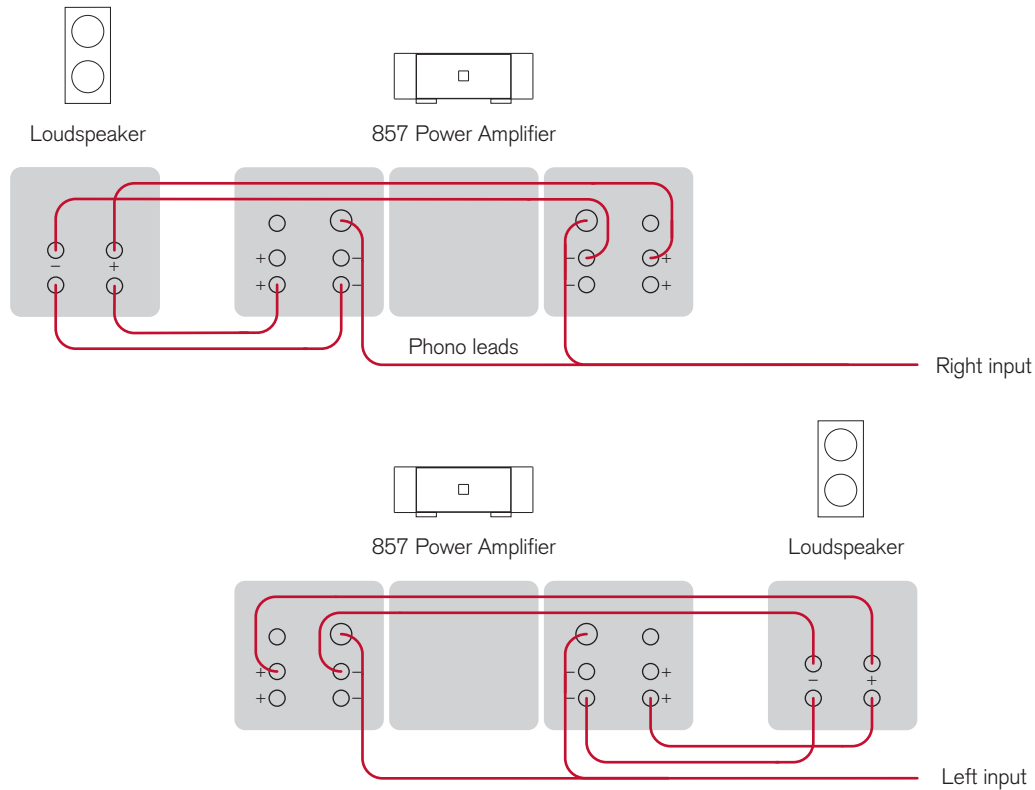

Extremely high sound quality can be achieved using two separate Rack Mount Two Channel Power Amplifiers, one to drive each loudspeaker. The two channels in each amplifier are used to drive the LF and HF units in each loudspeaker.

- Switch the Bridge Mode Selector on both amplifiers to the Off position.

Important: Remove the links bridging the LF and HF terminals on the back of each loudspeaker.

- Connect the red and black terminals from the LF and HF units on one loudspeaker to the red and black terminals on each channel of one amplifier.
- Likewise, connect the LF and HF units from the other loudspeaker to the red and black terminals on each channel of the other amplifier.
- Connect the left audio output from the preamplifier to both inputs on one amplifier.
- Connect the right audio output from the preamplifier to both inputs on the other amplifier.

To connect to a Meridian 861 Reference Digital Surround Controller

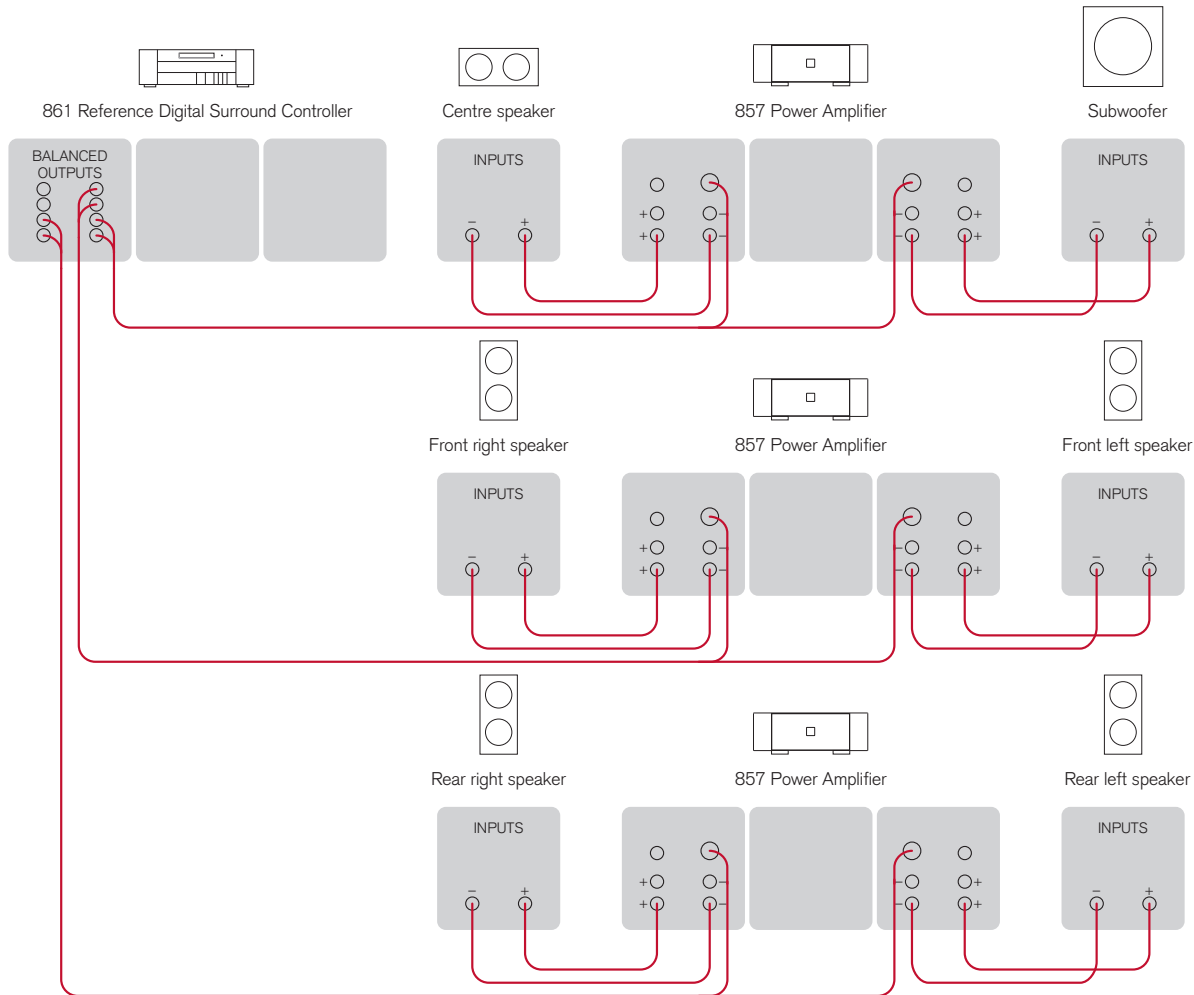

You can use three Rack Mount Two Channel Power Amplifiers to drive the five loudspeakers and subwoofer in a surround system, using the six of the balanced outputs available on the OA18 cards.

- Connect the balanced outputs from the 861 Reference Digital Surround Controller to the appropriate inputs on the 857 power amplifiers.

Troubleshooting

No front-panel indicator is shown

- Check that the AC power supply is connected correctly.
- Check that the **ON OFF** switch on the back panel is in the **ON** position.
- Check that the fuse in the rear panel has not blown.
Caution: Replace it with the same type and value of fuse.
- Check that the fuse in the unit's power plug has not blown.

The sound has cut out

The Rack Mount Two Channel Power Amplifier includes a thermal shutdown, which mutes the output if the amplifier becomes too hot. The front panel indicator will change to red.

- Leave the amplifier for a few minutes to cool down; the front panel indicator will turn amber and the output will be unmuted.

The Rack Mount Two Channel Power Amplifier also includes a trip to protect the loudspeakers. This is triggered by excessive DC on the input, extreme thermal overload, or if the mains supply is interrupted. The front panel indicator will be blank.

- Check the system for the cause of the cut out.
- Switch off, wait five seconds, then switch on to reset the power.
- For more information see *Operation*, page 7.

Maintenance

To clean the case

- Disconnect the power cord before cleaning the unit.

The exterior surfaces of the Rack Mount Two Channel Power Amplifier are made from solid anodised aluminium, powder coated steel, thermoplastic rubber, and glass.

They are designed to be easily wiped clean with a dry, lint free cloth. Greasy marks should be removed by light rubbing with a slightly damp cloth and a trace of proprietary glass cleaner. Do not use any other solvent or abrasive based cleaners.

Ensure that no liquid enters the casework and that the product is completely dry before re-connection.

To clean the audio connections

The audio sockets on the back of the product are gold plated and do not need to be cleaned if gold-plated phono plugs are used. Otherwise, it is recommended that you unplug and reconnect the plugs at least once a year. A proprietary contact cleaner can be used to some advantage.

Service and guarantee

Service

The Meridian 800 Series of hi-fi components has been carefully designed to give years of untroubled service. There are no user-serviceable parts inside the case, nor do the units require any form of maintenance.

In the unlikely event that your product fails to function correctly, it should be returned, in its original packaging, to your Meridian dealer.

In case of difficulty within the UK or USA please contact the appropriate sales and service address shown on page iv.

In case of difficulty outside the UK or USA, contact the importing agent for the territory. A list of Meridian agents outside the UK is available from Meridian Audio.

No responsibility can be accepted for the product whilst in transit to the factory or an agent, and customers are therefore advised to insure the unit. When seeking service under guarantee, proof of the date of purchase will be required.

Guarantee

The product is guaranteed against defects in material and workmanship for three years from the date of purchase, with an additional two years available via registration.

The guarantee is void if the product has been subject to misuse, accident, or negligence, or has been tampered with or modified in any way without the written authorisation of Meridian Audio Limited. Attempted servicing by unauthorised people may also invalidate this guarantee. Labour and carriage charges are not covered unless by local agreement.

Outside the UK, local warranty liability is restricted to equipment purchased within the territory. Our agents outside the UK are only under contractual obligation to service under-guarantee equipment sold through them. They are entitled to make a non-refundable charge for any service carried out on other equipment.

This guarantee does not limit your statutory rights within the country of purchase.

